

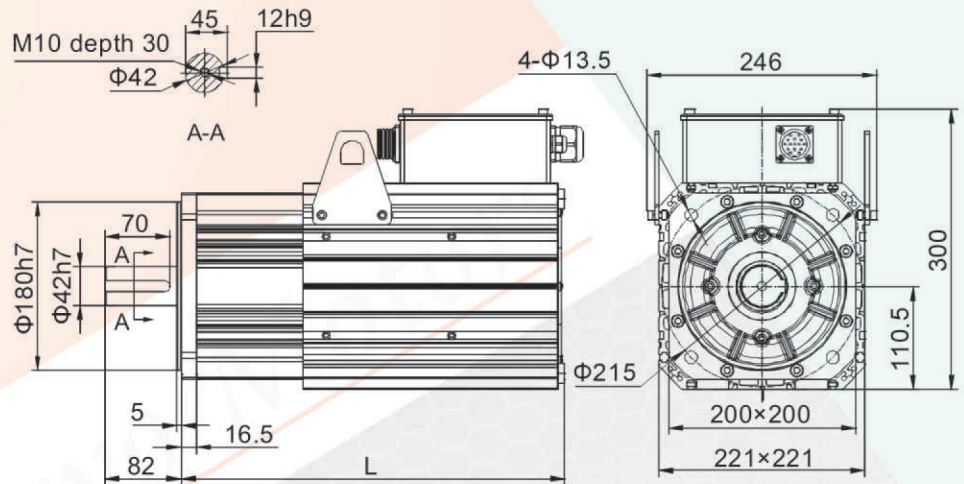

GL-A-MH20-015B-4

P.M. A.C. SERVO MOTOR



Motor model (2500-PPR/multi-turn absolute value/rotary transformer)	L(mm)		
	W/o brake	Permanent magnet brake	Electromagnetic brake
GL-A-MH20-015B-4-□A□	446	582	582

RATED POWER	15 Kw	STATOR RESISIANCE	NOT AVAILABLE
RATED VOLTS	380 V	STATOR REACTANCE	NOT AVAILABLE
MODE OF CONNECTION	Y	ROTOR RESISIANCE	NOT AVAILABLE
RATED FREQUENCY		ROTOR REACTANCE	NOT AVAILABLE
RATED CURRENT	42.5 A	EXCITATION REACTANCE	NOT AVAILABLE
RATED TORQUE	95.5 Nm	EXCITING REACTANCE	NOT AVAILABLE
REFERENCE SPEED	1500 r/min	INSULATION GRADE	F
MAX SPEED	2000 r/min	LEVEL OF PROTECTION	IP : 54
MOMENT OF INERTIA	119/127 kg/cm ²	SERIES	4 P
RATING		WEIGHT	56/73 Kg
COOLING FAN	RATED POWER RATED VOLTS		
ENCODER	IMPULSES PER MINUTE OUTPUT MODE	2500 TTL/HTL	
BRAKE RIGGING	NAME THE DATA PARAMETER	ELECTROMAGNETIC	